

TRANS-05, Torque Tube Removal, Rebuilding, and Installation

Tools

- Metric Wrench Set
- Metric Socket Set
- Jack Stands (6 minimum)
- Floor Jack
- 8mm Cheesehead socket (also referred to as 12 point internal socket and by Snap-On as a triple square socket) - for removal of CV joint bolts
- Transmission Jack (not absolutely required but makes transaxle removal much easier - borrow or rent one)
- See Rebuilding Section for bearing puller tools

Removal

1. Slightly loosen the lug nuts for both rear wheels.
2. Raise the vehicle on jack stands.
3. Remove both rear wheels.
4. Remove the exhaust system as follows:
 - a. On N/A cars remove the exhaust system from the flange at the exhaust manifolds back.
 - b. On turbocharged cars remove the exhaust system from the turbocharger outlet downpipe flange (just above the O2 sensor) back.

NOTE

The procedure and pictures that follow show the suspension being lowered after the transaxle has already been removed. It has been suggested that lowering the suspension first may make the transaxle removal easier. However, you'll likely find dropping the suspension first will not give you enough room to crawl up under the car to remove the transaxle.

5. Using [TRANS-03](#), remove the transaxle from the vehicle.
6. Remove the shifter rod.

7. Lower the rear suspension as follows:
- . Place jack stands or blocks under the swing arms.
 - a. Remove the front two bolts (one on each side of the vehicle) that hold the rear suspension to the chassis.



- b. Next, remove the four bolts (two on each side of the vehicle) half way up the wheel arch and the two bolts (one on each side of the vehicle) at the top of the wheel arch.



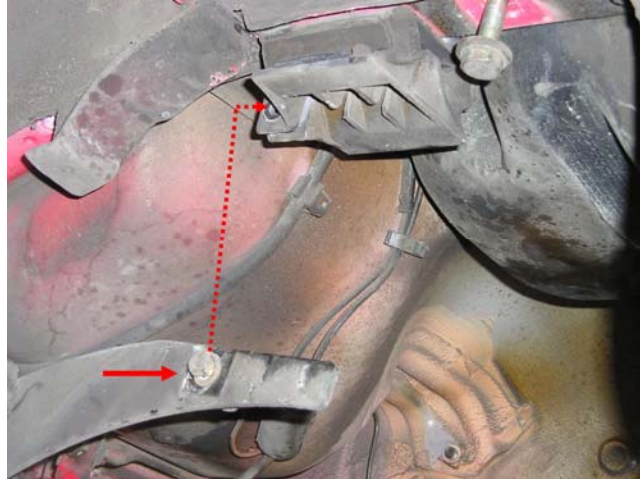

c. Loosen the bottom shock mount.



d. Disconnect wires and brake lines as necessary to lower the rear suspension without damaging them.





- e. You can now lower the rear suspension. However, the rear brake lines will limit the amount that you can lower the suspension. You may have to disconnect the brake lines to obtain enough clearance to remove the torque tube. Resting the lower suspension on blocks or bricks works well.



NOTE

8. It may be necessary to remove the starter and slave cylinder in order to access all the bolts / fasteners for the torque tube and torque tube carrier.
9. Remove the four bolts that connect the torque tube to the clutch housing.
10. Disconnect the torque tube carriers.

11. Lower the torque tube and move towards the rear of the car. If you're working with a late model 944 (dog ears on the torque tube), you will have to rotate the torque 180° to remove it from the car.

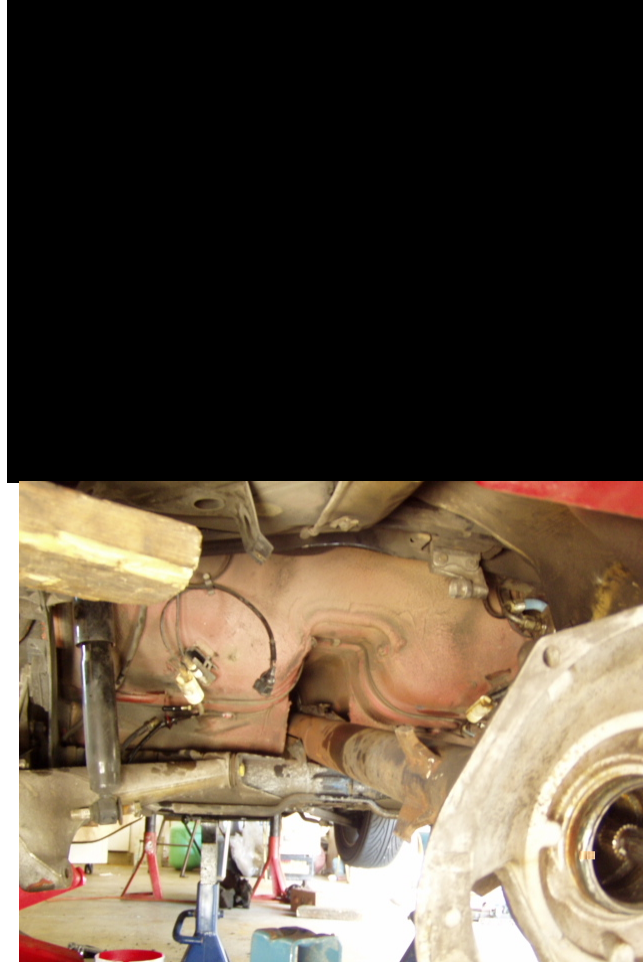

Rebuilding

1. Measure the distance from the transmission end of the drive shaft to the bellhousing end of the tube and record it. This is so the drive shaft end can later be reinstalled to the correct depth in the torque tube.
2. Get a 6 foot long piece of standard black or galvanized 1/2" steel plumbing pipe at the hardware store. Slip the end of this pipe over the pilot diameter at the front of the drive shaft.
3. Use a large hammer to pound the shaft out, towards the bellhousing side of the torque tube. The steel plumbing pipe is soft and will not damage the heat-treated splined drive shaft.
4. Once the shaft has been removed, you will need the following:
 - o A 6-foot long 3/4-10 threaded rod
 - o Five 3/4-10 nuts
 - o Two thick flat washers which will fit inside the tube I.D. and reasonably close to the O.D. of the threaded rod (I used heavy-duty fender washers). I went to Lowe's in their specialty bolts section.
 - o A flat bar or spacer of steel with a 1" hole in it (I used an old go-cart engine sprocket - anything which has a 1" hole in it and is larger than the small end of the torque tube which can be pressed against without deflecting will work).

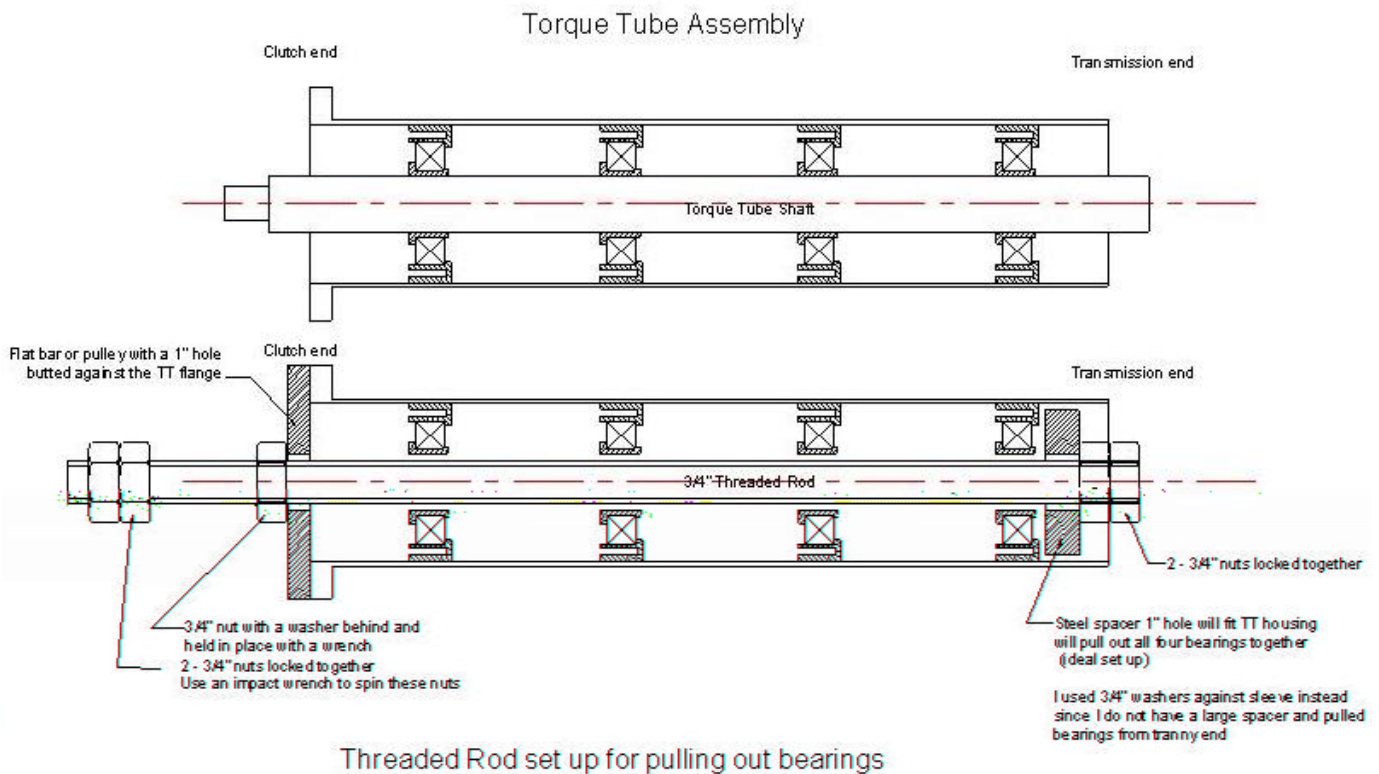

5. Slide the spacer or the large washer on one end of the threaded rod, then lock two nuts together near the end of the rod. You may find it works well to place a large socket in front of the washers to act as a "driver" to pull the bearings out.



6. Slide the rod into the tranny bellhousing end of the torque tube.



7. Put the go-cart pulley or the flat bar with 1" hole onto the protruding end of the threaded rod at the front of the torque tub
8. Add a washer and nut. This nut will be held stationary with a wrench. Alternatively, if you have a welder, you can tack weld the nut to the flat bar.
9. Lock two nuts together at the protruding end of the threaded rod in front of the torque tube.
10. Hold the $\frac{3}{4}$ " nut which bears against the pulley or flat bar with a 1" hole with a wrench.

11. Use an impact wrench to "spin" the two locked nuts at the front of the threaded rod, spinning it counterclockwise. This drags the washer at the bellhousing end forward, accumulating the 4 bearings as it goes. Can also do this by hand, but it takes forever. Alternatively, if you don't have an impact wrench, you can simply turn the $\frac{3}{4}$ " nut against the flat bar with an open end or combination wrench. Again, it will take a long time. The picture below shows a puller with a flat bar on the end and one with a go-cart pulley.

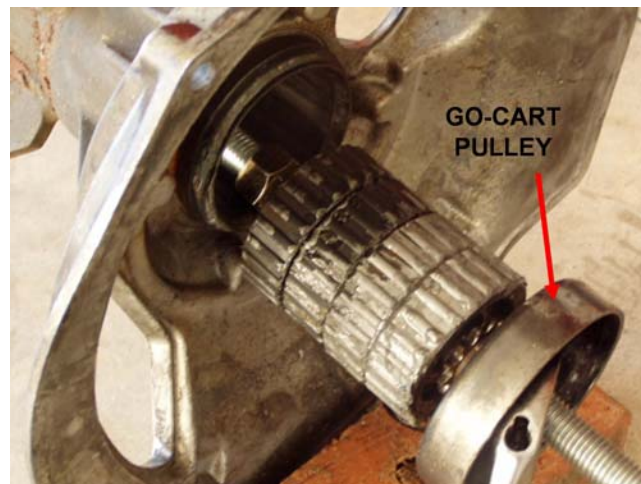

12. After so many turns (a million), presto - out pop all 4 torque tube bearing assemblies.

NOTES

After removing these, their construction is evident - they are standard sealed ball bearings FAG 6006 2Z that are pressed into stamped steel carriers with rubber splines molded onto the O.D. There are also little rubber-covered inner sleeves that are pressed into the I.D. of the sealed bearings, that are staked in 4 places. You need to "unstake" the sleeves and remove them, then press the bearings out of the carriers, and press in new ones. On older 944s, the bearing carriers are two-pieces that are riveted together. You'll need to drill the rivets out and separate the two halves of the carrier to remove the bearing.

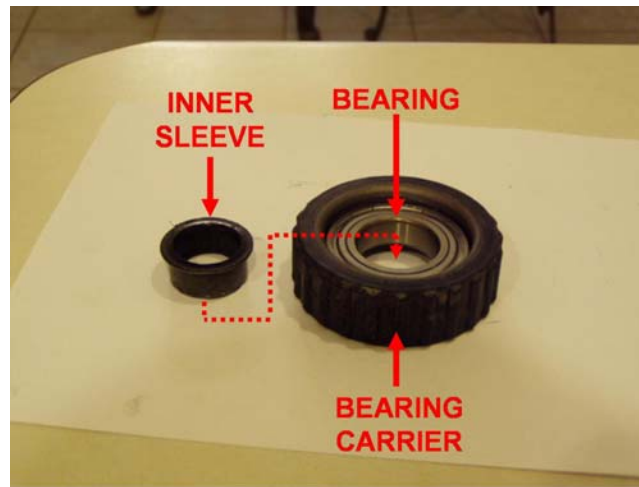

If the rubber coated inner sleeves are intact, once you've pressed them out of the bearings, save them for reuse. However, if they are shattered or are in otherwise poor condition, you'll need to have new sleeves fabricated. I went to a machine shop to have them fabricate 4 of the inner sleeves out of Delrin plastic (see drawing below).



Material used according to machine shop was Delrin plastic. Do not use UHMW. It is too soft.

After installing sleeve in bearing (6006-2RS) recheck the sleeve inside dia. (25.10mm). To make sure it is a very slight interference fit to the TT shaft. If it's too tight, you may have a hard time installing the TT shaft and indent the ball bearings and races while trying to hammer it in.

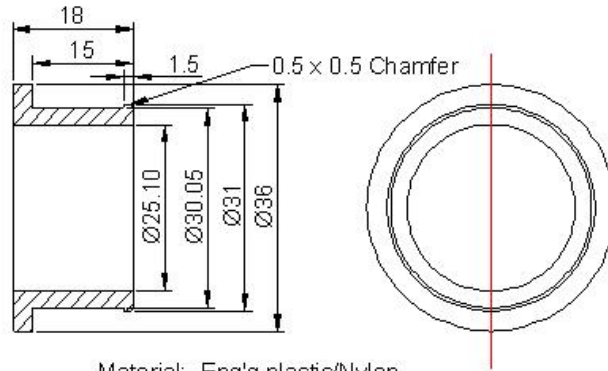

Material: Eng'g plastic/Nylon
Qty: 4 pcs.
Dimension: mm

I used a hydraulic press to install the new bearings and inner sleeves.

13. Install the bearing assemblies and drive shaft in the torque tube as follows:
 - a. Measure and mark 1st, 2nd, 3rd & 4th bearing locations in the torque tube with 1st in front. Use bearing marks in the shaft.
 - b. All 4 bearing housings must be in same orientation. Look at the attached dwg. Position inner sleeve in a way it will not come out when the shaft is driven from the front end of torque tube. Whether you are reusing the old sleeves or using new ones.
 - c. Install 2nd bearing in the front end using the 3/4" all threaded rod until it is in the second bearing mark. Then do the 1st bearing.
 - d. Then install the 3rd and 4th bearing from the back end. I did it this way so I don't have to install one bearing from the front end all the way to the back end. That is a lot of wrenching. I put some loctite anti-seize inside the torque tube so bearing will slide easy.
 - e. Insert the drive shaft into torque tube from the front end inserting the tranny end first. I used a plastic mallet to tap it in. Once it hit the 4th bearing it got a little stiff so I had to use a 1/2" x 2" pipe inserted in the pilot bearing end then hit it with a ball peen hammer (not too hard!). Position the shaft based on the measurement before disassembly.
 - f. The key here is to have the sleeve ID to have the right tolerance fit. If it's too tight, you have to hammer the shaft really hard to drive it in thus destroying the ball bearings due to shock load during installation. If it is too loose, it may not last long and vibrate soon.

Installation

1. Slide the torque tube back into position in the vehicle. Remember, if this is a later torque tube with dog ears, the transaxle will have to be rotated 180° from its normal orientation to get it to slide into position.
2. When the torque tube is in position such that the front flange is near the clutch housing, rotate the torque tube back to its normal orientation (if it's a torque tube with dog ears). Then move the torque tube forward until the drive shaft slides into the pressure plate and clutch disc and the torque tube flange is flush with the clutch housing. Support the back end of the torque tube with a jack stand.
3. Install the torque tube carriers and the retaining bolts (4) for the torque tube to clutch housing flange.
4. Raise the rear suspension and install retaining bolts. Reattach and lines that were disconnected when the suspension was lowered.
5. Attach the lower shock mounts to the suspension.
6. Using [TRANS-03](#), install the transaxle.
7. Install wheels and tighten lug nuts.

Clark's Garage © 1998
